



**Fashioning your Future**  
Tajima always leads. never follows

# TMEZ-SC

LA PRIMERA EN EL MUNDO

Una bordadora innovadora  
con ajuste automático  
de la tensión..

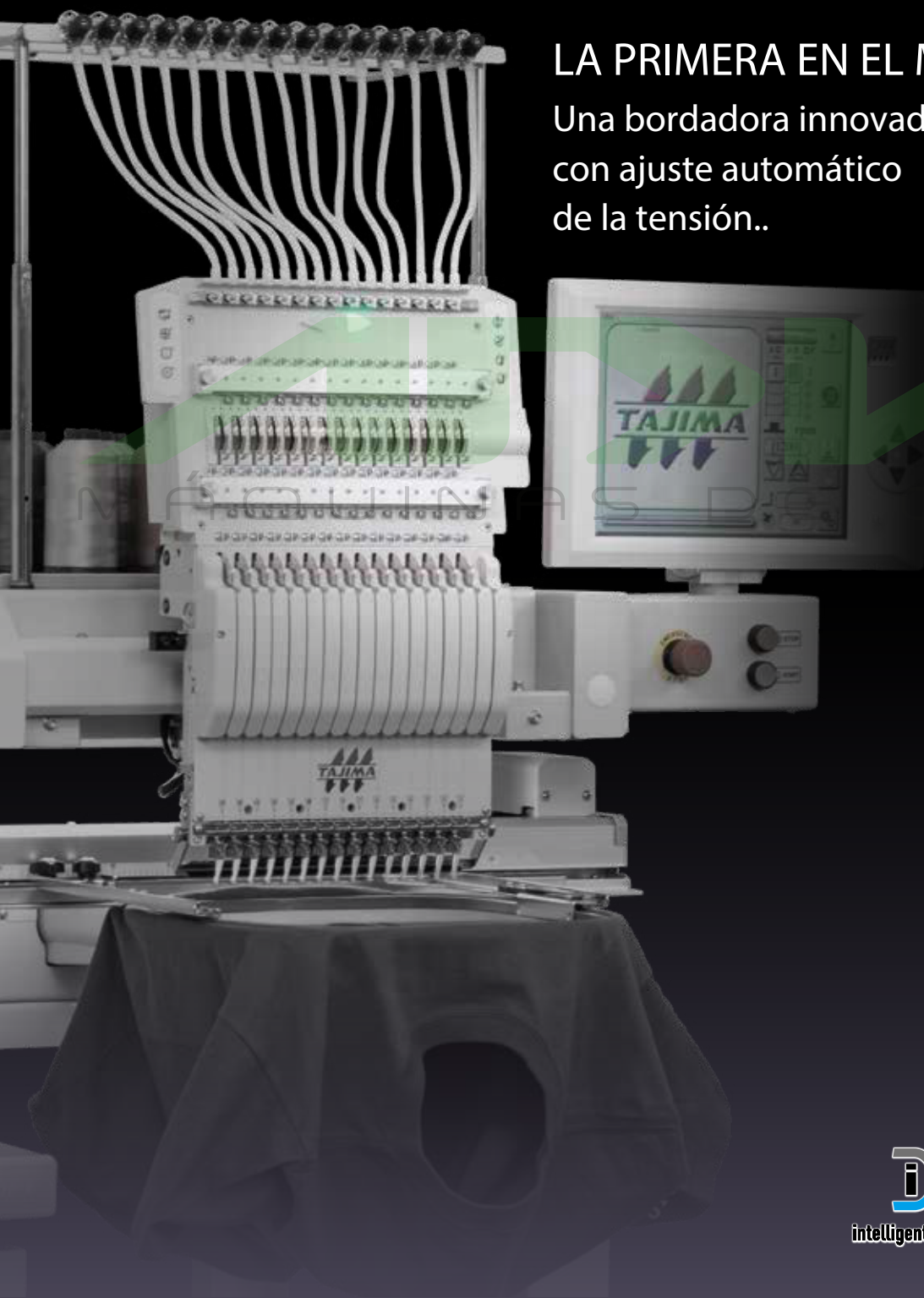

intelligent Thread Management



digitally controlled Presserfoot

What is it about

**i-TM** provides optimal tension adjustment.



No need for fine adjustment!

Consistent production!

### i-TM solves these issues

- Requires thread tension adjustment after thread replacement.
- Requires operator skill and experience.
- The quality of the embroidery finish is inconsistent.
- The fabric is easily shrunken by embroidery stitch pulling.

i-TM is mounted on the tension base in place of the previous tension knobs.

### Improved production efficiency

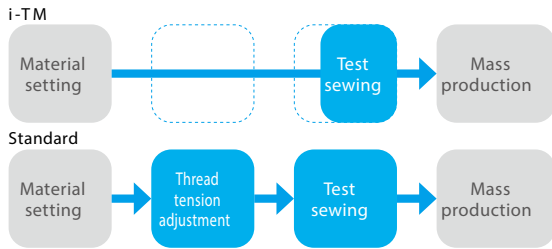

As the appropriate thread tension adjustment is applied regardless of the thread type, mass production can be started quickly.

A high quality embroidery finish is achieved regardless of thread type and fabric used.



It is possible to embroider without adjusting the upper thread for various thread types and thread colors such as cotton thread and metallic thread as well as polyester and rayon thread.

### Features

The new "Picker free" trimming system has been adopted

The new improved "Picker Free" ATH system is able to stabilize trimming and enhance production efficiency. Besides that, it is much easier to replace a bobbin without the picker in the way.



DCP -Digitally Controlled Presser Foot-

The height of the presser foot can be randomly set according to the material thickness on the operation panel. The fabric does not flutter even when using hard-to-embroider materials like leather, thick fabric, stretchy fabric and quilting.



View by video clip.



12.1 inch TFT Touch Monitor

The embroidery process can be monitored in real time on a large monitor. An operation panel with excellent operability allows intuitive embroidery finish settings.



### Specifications

Needles	9,12,15
Factory options	Position Marker, LED Lamp
Dealer options	Stand, Stand Tray, Border Frame, Cap Frame 2
Revolution	Max. 1,200 rpm
Electricity	Single-phase 100-120V, 200-240V, 50Hz/60Hz
Power consumption	160W
Weight	95kg

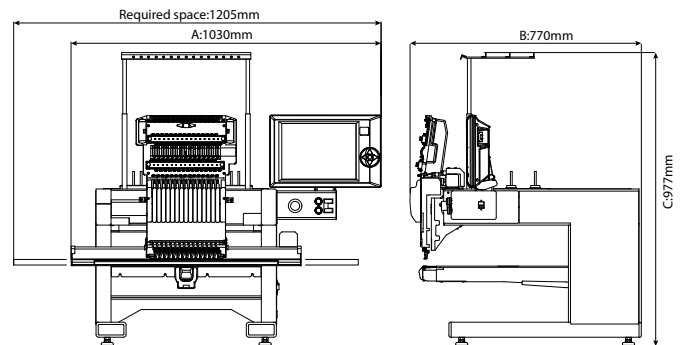

Seller

**Tajima Industries Ltd.**

NO.1800 Ushiyama-cho, Kasugai, Aichi-pref. 486-0901 JAPAN  
TEL : +81-568-90-6512,6514, 6518  
FAX : +81-568-90-6513,6515, 6519



<https://www.tajima.com>



<https://www.facebook.com/TajimaGroup>

Manufacturer

**TISM Co.,Ltd.**

Please contact our distributor listed below.

**ADWSA** 1994  
MÁQUINAS DE COSER



**WWW.ADWSA.COM**

@adwmaquinasdecoser

@adwmaquinasdecoser

/adwmaquinas

+57 3142386998

info@adwsa.com

/adwmaquinasdecoser

\* The actual embroidery area and embroidery speed may vary depending on the items being produced, the machine model, and the embroidering conditions.  
\* Caution: No registered trademark or product design contained in this catalog may be used without prior permission from the manufacturer.  
\* The specifications and designs of our products are subject to change without notice for performance improvement.